

Technical Documentation

IRS-20/21 (Intelligent Road Sensor)

Version 1.0

Status: 30.6.2000

Authors: H-J. Mechler, J. Groß, A. Schmitz-Hübsch,

Project: 9907

G. Lufft

Meß- und Regeltechnik GmbH

Gutenbergstraße 20

D - 70736 Fellbach

Germany

Telephone +49 (0) 711/51822-0

Fax +49 (0) 711/51822-41

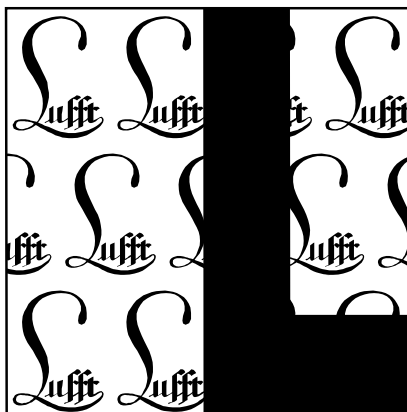

Lufft

Table of Contents

<u>1</u>	<u>GENERAL</u>	<u>4</u>
<u>2</u>	<u>STORAGE CONDITIONS</u>	<u>5</u>
<u>3</u>	<u>OPERATING CONDITIONS</u>	<u>5</u>
<u>4</u>	<u>APPROVALS</u>	<u>5</u>
<u>5</u>	<u>QUALITY</u>	<u>5</u>
<u>6</u>	<u>SYSTEM DESCRIPTION</u>	<u>6</u>
<u>6.1</u>	<u>HARDWARE</u>	<u>6</u>
<u>6.2</u>	<u>THE INTERFACES</u>	<u>8</u>
<u>7</u>	<u>MOUNTING AND INSTALLATION</u>	<u>10</u>
<u>8</u>	<u>COMMISSIONING AND TESTING</u>	<u>13</u>
<u>9</u>	<u>MAINTENANCE</u>	<u>14</u>
<u>10</u>	<u>WIRING DIAGRAM</u>	<u>16</u>

<u>11</u>	<u>IRS-20/21 PROTOCOL</u>	17
<u>11.1</u>	<u>INTRODUCTION</u>	17
<u>11.2</u>	<u>PROTOCOL DESCRIPTION</u>	18
<u>11.2.1</u>	<u>BINARY PROTOCOL (IRS-21 <-> S2S)</u>	18
<u>11.2.2</u>	<u>BINARY PROTOCOL (IRS-20 <-> HOST COMPUTER)</u>	20
<u>11.2.3</u>	<u>ASCII-PROTOCOL (IRS-20/21 <-> HOST COMPUTER)</u>	23
<u>11.2.4</u>	<u>BINARY PROTOCOL (IRS-20 VIA OPUS200/300 <-> HOST COMPUTER)</u>	26
<u>11.3</u>	<u>PHYSICAL CONNECTION AND HARDWARE STRUCTURE</u>	26
<u>11.4</u>	<u>SOFTWARE PROTOCOL</u>	26
<u>11.5</u>	<u>TELEGRAM AND DATA FORMAT</u>	27
<u>11.6</u>	<u>CONFIGURATION OF THE OPUS200 MODULE</u>	29

1 General

The IRS-20/21 Road Sensor serves to monitor the road condition.

In contrast to most other sensors on the market, the road condition is captured directly within the sensor. This is made possible by means of a controller with transmission capability and a patented procedure for water film measurement.

The road condition is derived from a sensor system consisting of the following components: surface temperature measurement, multi-frequency measurement, freezing temperature measurement and water film height on the sensor surface.

Dependent on the measured values, the software of the IRS20/21 uses correlation factors to calculate the likely road condition.

Above a nominated temperature "TPOS", the model recognises the conditions "Dry", "Residual Salt", "Damp" and "Wet". Below "TPOS" are the additional conditions "Freezing Wetness", "Frost / Dry Snow" and "Ice / Wet Snow".

The IRS-20 supports communications protocol with a host computer.

The IRS-21 supports the direct control of prism signs.

The sensor has the following additional characteristics:

- Compact construction and easy installation
- Low maintenance
- Resistant to physical and chemical influences
- Exchangeability possible even in installed condition
- Data transmission via RS485
- Measurement time < 2s, thereby low energy consumption

2 Storage Conditions

Permissible ambient temperature	:	-30°C ... +70°C
Permissible relative humidity	:	0...100 % relative humidity

3 Operating Conditions

Permissible ambient temperature	:	-30°C ... +70°C
Permissible relative humidity	:	0...100 % relative humidity
Protection Class	:	IP68

4 Approvals

Design conforms to CE

5 Quality

Guarantee period	:	12 months
Maintenance interval	:	annually

6 System Description

6.1 Hardware

The sensor consists in principle of two components:

- Basic housing with connection cables for communication and power supply
- Housing cover with sensor electronics and evaluation electronics

These components are joined together by 6 screws.

Two concentric circles on the sensor surface provide the measurement values for the multi-frequency measurement. Alongside, in a recess, there are two electrodes that provide information about salt concentration and thereby the freezing temperature. Additionally, a temperature sensor, which determines the surface temperature, is installed in the central electrode.

Beneath the remainder of the surface is the aerial for the CW-Radar, by means of which the water film height above the cover can be determined.

The printed circuit board, which contains the signal conditioning and evaluation electronics, is also directly connected to the cover. Data is output via an RS485 interface.

Important: Power consumption during measurement is approximately 200mA. In order to exclude measurement errors through self-heating, the IRS-20 must only be supplied with power for approx. 2s. After data interrogation, therefore, the sensor must be free of voltage. The measurement interval must be >1 minute. This does not apply to the IRS-21.

The schematic unit diagram of the IRS-20/21 is shown in Illustration 1.



Abb.1: IRS-20/21 Schematic Unit Diagram

6.2 The Interfaces

Illustration 3 shows three possible combinations by means of which the IRS-20/21 can communicate with terminal devices.

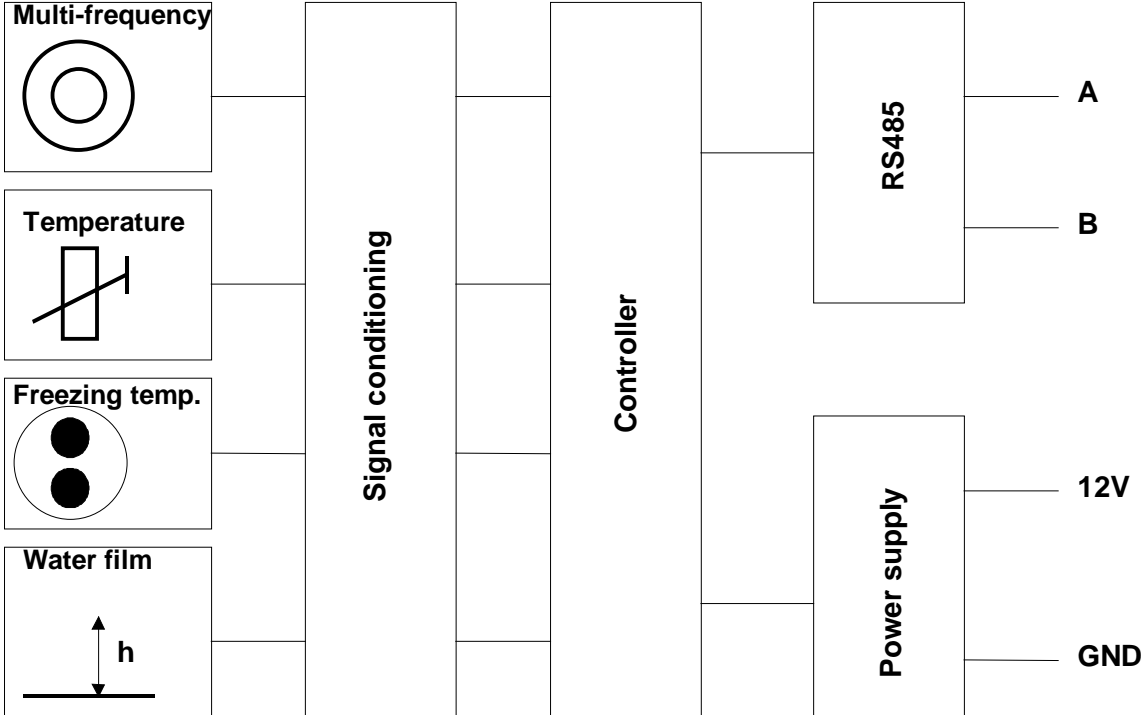
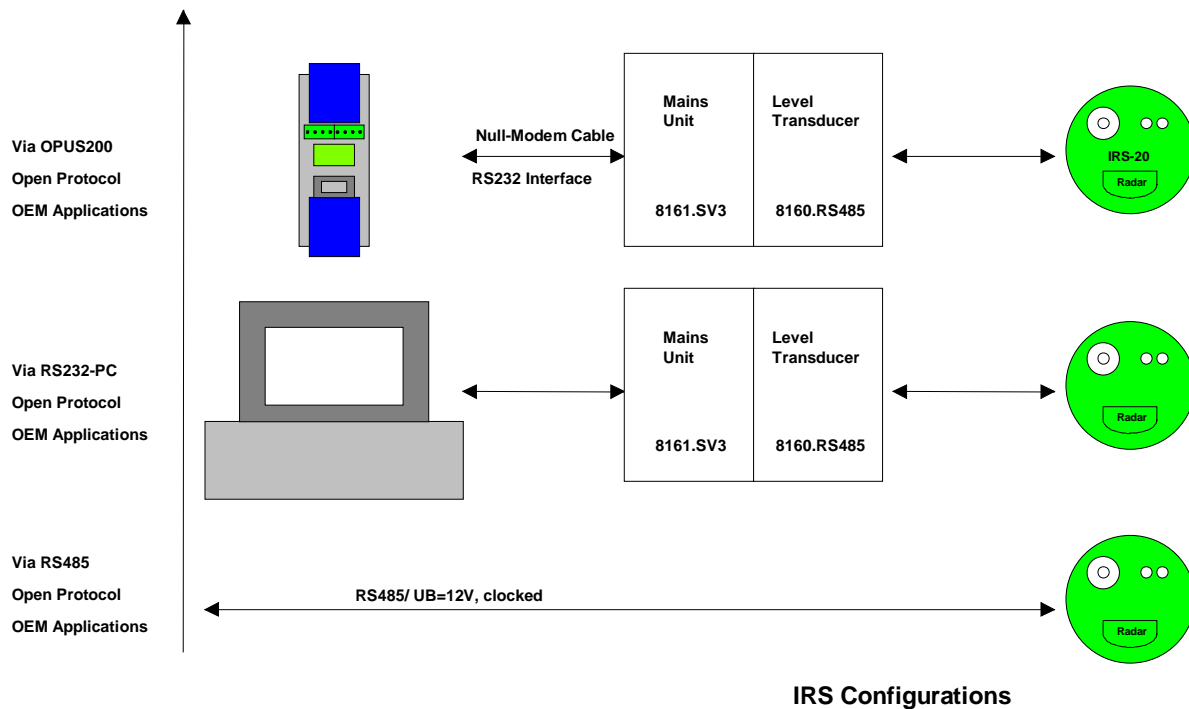

Illustration 2: IRS-20/21 Connection Possibilities

The combination IRS-20 and OPUS200 is useful when, in addition to the IRS-20 data, additional measurement values are to be distributed via a common interface. Interrogation takes place via the RS232 interface of the OPUS200/300.

The combination IRS-20 and PC (RS232 terminal device) can be applied when the terminal device has an RS232 interface. RTS/CTS control circuits switch both the readiness to transmit / receive and the power supply of the IRS-20/21. This hardware functionality is contained in the combination Mains Unit (8161.SV3) and Level Transducer (8160.RS485). The terminal device software is responsible for ensuring

that the power supply is not connected for more than 2 seconds. The measurement interval must be >1 minute.

The same conditions apply when the sensor is interrogated directly via the RS485 interface.

The protocols are described in the Appendix.

7 Mounting and Installation

The road sensor is installed in the centre of the road lane. On two lane carriageways installation takes place in the left-hand lane.

Preparation

A hole of diameter $D > 16$ cm and depth $T = 6$ cm is required for the sensor.

A slot of width 2 cm and depth 5 cm is to be cut in the road lane for the supply lead.

Attention! On bridge constructions take care that the insulation is not damaged (a depth of 6 cm can not always be maintained in every case).

Mounting

The cable screw joints must never be opened. Shortening of the supply lead is only permissible at the control panel end of the supply lead.

The road sensor is placed into the hole provided in such a way as to finish flush with the road surface. For this purpose, the installation aid, which is already mounted on delivery, is placed on the road surface. Using the spirit level provided, check that the road sensor is installed horizontally. Where necessary the sensor can be aligned by bending the installation aid. **Under no circumstances must the road sensor project beyond the road surface (damage by snow clearers).**

The cavities are filled in with concrete. Remove the installation aid after the concrete has set. The fixing screws are installed in the open holes of the sensor.

Connection of the Supply Lead

The road sensor supply lead is connected with the power supply and the bus system of the evaluation electronics in the control panel.

Connection of the road sensor supply lead:

Brown Positive power supply

White Negative power supply

Yellow RS485_A

Green RS485_B

Attention: Errors in connection will destroy the road sensor.

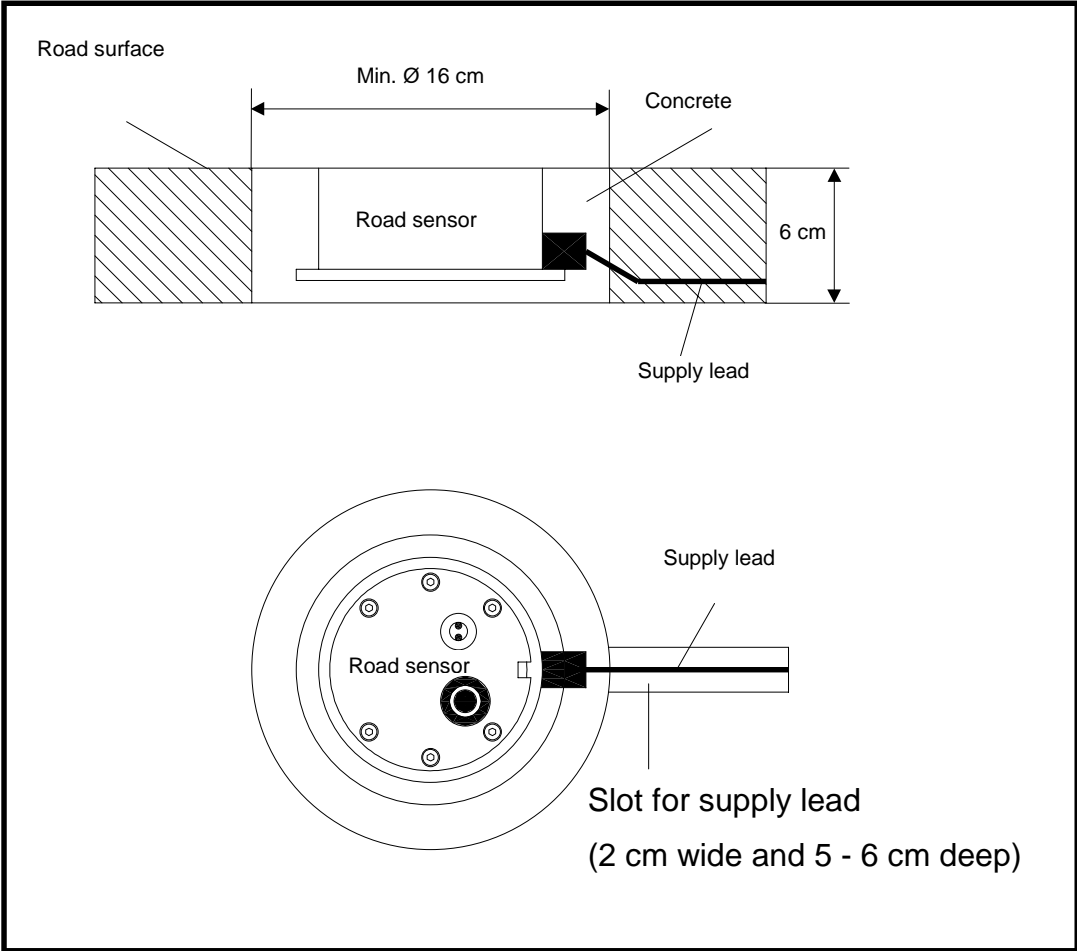

IRS20/21 Installation in the road

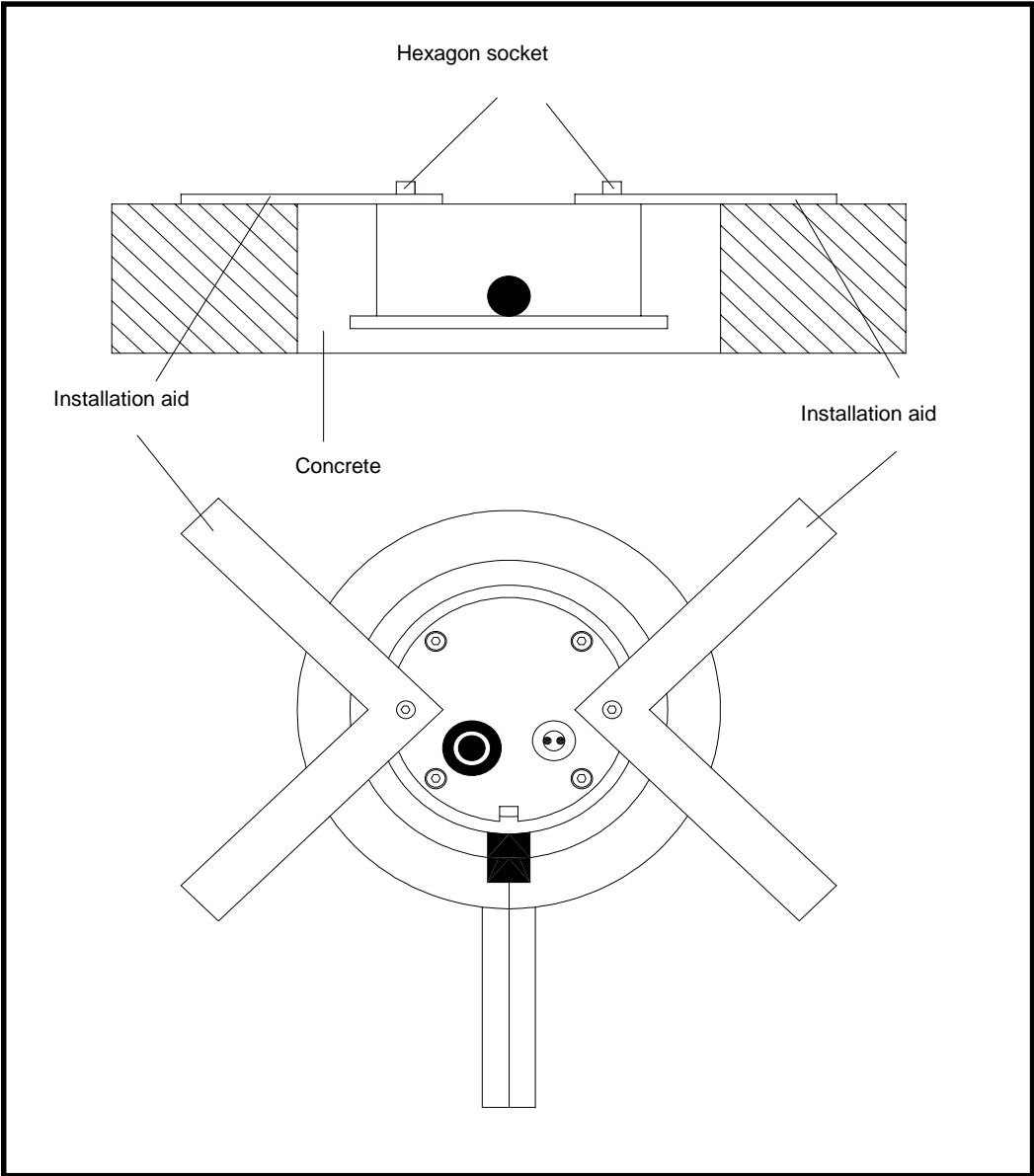

Mounting the IRS20/21

8 Commissioning and Testing

After successful installation of the road sensor, check the functional capability. For this purpose use the product IRS-Check and a Laptop.

Connect the sensor to your evaluation device and check whether communications between sensor and evaluation device are operating correctly. The road condition calculated by the evaluation device should be checked with sensor in both wet and dry condition.

9 Maintenance

The road sensor should be serviced annually. This includes the visual inspection of the housing and a functional check using IRS-Check. It is recommended to clean the sensor surface when very dirty. Where there is significant mechanical damage to the sensor, which could influence the tightness of the housing, it is recommended to exchange the sensor. This also applies in the case where the plastic assembly of the sensor is heavily degraded by wear and tear.

Function Testing

The testing is carried out using IRS-Check and a Laptop. See IRS-Check operating instructions.

Exchange of Sensor Electronics

If the plastic assembly of the road sensor becomes unserviceable due to mechanical effects, or the sensor electronics are damaged, the plastic assembly can be exchanged without the need to exchange the entire housing.

Exchange must only be carried out when the road is dry.

To uninstall the plastic assembly remove all six hexagonal screws. On the edge of the cover there is a small opening that serves to provide access for a screwdriver. Thereby the plastic assembly can be lifted out. Take care not to pull out the connection cables on the underside of the sensor. The plug connections must be removed without tensile strain on the cables.

When exchanging the sensor electronics the ring gasket must be renewed on each occasion.

Before installing the new sensor the housing should be cleaned thoroughly. Even minor contamination of the gasket seat will lead to failure of the sensor in the long term. Humidity must not be permitted to enter the housing.

When attaching the connection plugs to the new sensor care should be taken not to touch the electronics of the sensor. Electrostatic discharge (ESD) will destroy the sensor.

The gasket should be installed using silicone grease. When installing the plastic cover the gasket must not bend out of line. The plastic cover must be placed in the housing without the application of force. Grease the threads of the fixing screws. First lightly fasten the screws and then tighten using a Phillips screwdriver.

10 Wiring Diagram

Colour coding of the IRS-20/21 connection cable:

Brown	Positive power supply
White	Negative power supply
Yellow	RS485_A
Green	RS485_B

11 IRS-20/21 Protocol

11.1 Introduction

An RS485 interface (2 wire, half-duplex) is installed for connection to master and slave systems.

In order to enable a flexible connection to various processing points, several interface protocols were built into the firmware of the IRS-20/21:

- Binary protocol for direct control of intelligent road signs (IRS-21)
- Binary protocol for connection to master host computer (IRS-20)
- ASCII protocol for direct output of measurement values (IRS-20/21).

The interface protocol of the OPUS200/300 is also described, for applications that require additional measurement values to be output via an RS232 interface.

11.2 Protocol Description

11.2.1 Binary Protocol (IRS-21 <-> S2S)

Parameter	Options on request	Factory setting
Baud rate	2400 - 38400 Baud	9600 Baud
Data bits	8 (fixed)	8
Stop bits	1 (fixed)	1
Parity	None, even, uneven	Even

Interface parameters for the binary protocol of the IRS-21

In this operating mode the IRS-21 is designed as the control unit (Master) and the connected road signs as subordinate units (Slaves). Up to 32 Slaves can be connected to the Master via the **RS485** interface.

The set-up of the transmission protocol is to be taken from the "Primenwender" interface specifications (Prism Signs Interface Specification Release 1.1 of the Bosch Company, date 02.10.98).

On commissioning, the IRS20/21 checks whether traffic signs are connected and records the corresponding bus addresses. Only these registered addresses are used for subsequent transmission. Should an error occur in subsequent data transmission, (e.g. no response from the traffic sign) an error flag is displayed for this Slave address. However, the Slave address remains recorded. In advance of each further transmission the road sensor checks by means of a test transmission whether the marked Slave is still faulty. If this is no longer the case the error flag is removed. The IRS-20/21 installed in the road, using its sensor electronics and evaluation logic, recognises the momentary road condition. This condition is transferred to an internal

matrix from which the corresponding prism page is selected. This is then sent as a telegram to the connected Slave(s).

11.2.2 Binary Protocol (IRS-20 <-> Host Computer)

Parameter	Options on request	Factory setting
Baud rate	2400 - 38400 Baud	19200 Baud
Data bits	8 (fixed)	8
Stop bits	1 (fixed)	1

Interface parameters for the host computer binary protocol

The IRS-20 supplies measurement data on receipt of a corresponding telegram from the Master host computer.

Telegram set-up (descending byte series)

Byte number	Meaning	Abb.	Range
1	Telegram start	STX	0x02
2	Length	CNT	1 ... 255
3	Command	CMD	0 ... 255
... n	Additional data	D0 ... Dn	0 ... 254 Bytes
n + 1	Block check	BCC	XOR - value of address up to last data byte
N + 2	Telegram end	ETX	0x03

Data inquiry from IRS-20 to host computer

Sensor is connected (CMD = 0x00):

Host: STX, CNT = 2, CMD = 0x00, D0, BCC, ETX

IRS-20: STX, CNT = 2, CMD = 0x00, Inverted D0 - value, BCC, ETX

Example: Host sends D0 = 0x55, IRS-20 responds with D0 = 0xAA

Inquiry of soft and hardware status (CMD = 0x01)

Host: STX, CNT = 1, CMD = 0x01, BCC, ETX

IRS-20: STX, CNT = 3, CMD = 0x01, D0 = HW, D1 = SW , BCC, ETX

Example: HW = 04 -> Hardware status 0.4; SW = 20 -> Software status 2.0

Inquiry of sensor data (CMD = 0x03)

Host: STX, CNT = 1, CMD = 0x03, BCC, ETX

IRS-20: STX, CNT = x, CMD = 0x03, D0 ... D11 (see Table), BCC, ETX

Slave D0 ... D11	Meaning
0 / 1	Internal temperature sensor (0 ... 2000 digits) (Byte 0 = Lowbyte, Byte 1 = Highbyte)
2 / 3	External temperature sensor – 1 (0 ... 2000 digits) (Byte 0 = Lowbyte, Byte 1 = Highbyte)
4 / 5	External temperature sensor – 2 (0 ... 2000 digits) (Byte 0 = Lowbyte, Byte 1 = Highbyte)
6 / 7	Byte 6 = Freezing temperature (0 ... 250 digits) Byte 7 = 0
8 / 9	Byte 8 = Water film height Byte 9 = 0
10 / 11	Byte 10 = Road condition (0 ... 99) Byte 11 = 0

Inquiry of EEPROM – Individual memory points (CMD = 0x04)

Host: STX, CNT = 3, CMD = 0x04, D0 = Lowbyte - address, D1 = Highbyte – address, BCC, ETX

IRS-20: STX, CNT = 5, CMD = 0x04, D0 = Lowbyte – address, D1 = Highbyte – address,
D2 = Lowbyte – Datum, D3 = Highbyte – Datum, BCC, ETX

Note: the address range of the EEPROM on the road sensor is from 0 ... 2047.

IRS-20 response on incorrect data from host computer:

IRS-20: STX, CNT = 1, NACK = 0x15 = Not Acknowledge (data were not accepted), BCC, ETX

11.2.3 ASCII-Protocol (IRS-20/21 <-> Host Computer)

Parameter	Options on request	Factory setting
Baud rate	2400 - 38400 Baud	19200 Baud
Data bits	8 (fixed)	8
Stop bits	1 (fixed)	1

Interface parameters for the ASCII-Protocol

Both IRS-20 and IRS-21 support this protocol.

In addition to the above-mentioned binary protocols, measurement values from the IRS-20/21 can be called up in clear text. For this purpose, terminal software that supports the conversion from RS232 / RS485 is needed.

The following rules apply:

- Each command must be preceded by an '&'.
- When several measurement values are transmitted (e.g. the values of the 3 temperature sensors), these are separated from one another by 1 'Space' (= 20h). Groups of measurement values (e.g. water film & road condition) are separated from one another by 3 'Spaces'.
- The termination of a transmission is always formed by 'CR & LF' (= 0Dh & 0Ah).

T↵	<p>Output of the normalised values of 3 temperature sensors:</p> <ol style="list-style-type: none"> 1. Value = External Sensor 1 2. Value = External Sensor 2 3. Value = Internal Sensor <p>The respective value range covers 0 ... 2000 Digits = -50.0 ° ... +150.0 °C. For a non-connected or defective sensor the value is always 'xxxx'.</p>
F↵	<p>Output of the normalised values of 4 frequencies of the multi-frequency measurement:</p> <ol style="list-style-type: none"> 1. Value = F1000k-Range

	<p>2. Value = F500k- Range</p> <p>3. Value = F200k- Range</p> <p>4. Value = F51k- Range</p> <p>The respective value range covers 0 ... 254 Digits.</p> <p>On dry road conditions the values are high, on damp / wet / frost conditions the values are low.</p> <p>For non-tuned or faulty frequency measurement the values are always set at 'xxx'.</p>
--	---

L↵	<p>Output of salt concentration / freezing temperature.</p> <p>1. Value = Concentration of the salt solution from 0 ... 250 Digits = 0.0 % ... 25.0% (NaCl)</p> <p>2. Value = Freezing temperature of the salt solution from 0 ... 250 Digits = 0.0 ° ... - 25.0 °C.</p> <p>When measurement can not be determined both values are set to 'xxx'. The measuring range for the determination of salt concentration is from -20 ... + 15 °C (internal temperature sensor).</p>
R↵	<p>Output of the normalised water film height in the range 0 ... 250 Digits.</p> <p>On dry road conditions the water film value tends towards 150 (= Dry). On increasing water level height the value moves in the direction of '000'.</p> <p>For non-tuned water film measurement the value is always set to 'xxx'.</p>
Z↵	<p>Output of the road condition calculated from the above measurement values in the range 0... 99:</p> <p>0 = Dry</p> <p>1 = Damp</p> <p>2 = Wet</p> <p>3 = Ice</p> <p>4 = Frost / Snow</p> <p>5 = Residual Salt</p> <p>6 = Freezing Wet</p> <p>98, 99 = undefined values (the road condition could not be calculated)</p>
A↵	<p>Output of all of the above-mentioned values in the sequence T, L, R, Z.</p> <p>Between the measurement groups 3 'Spaces' (= 20h) are always given.</p>

	<p>The error status of the sensor is also transmitted at the end of the line</p> <p>The following error conditions have been defined:</p> <p>'000' = The unit is in order</p> <p>'001' = The external temperature sensors are not connected or are faulty</p> <p>> '001' = The unit is faulty</p>
∇,↓	<p>Edition of the hardware and software version.</p> <p>e.g. 0.4 (= HW Version) 2.0 (= SW Version) 16.06.00 (SW creation date)</p>

Example of data output after the command &A,↓ sent by the host computer

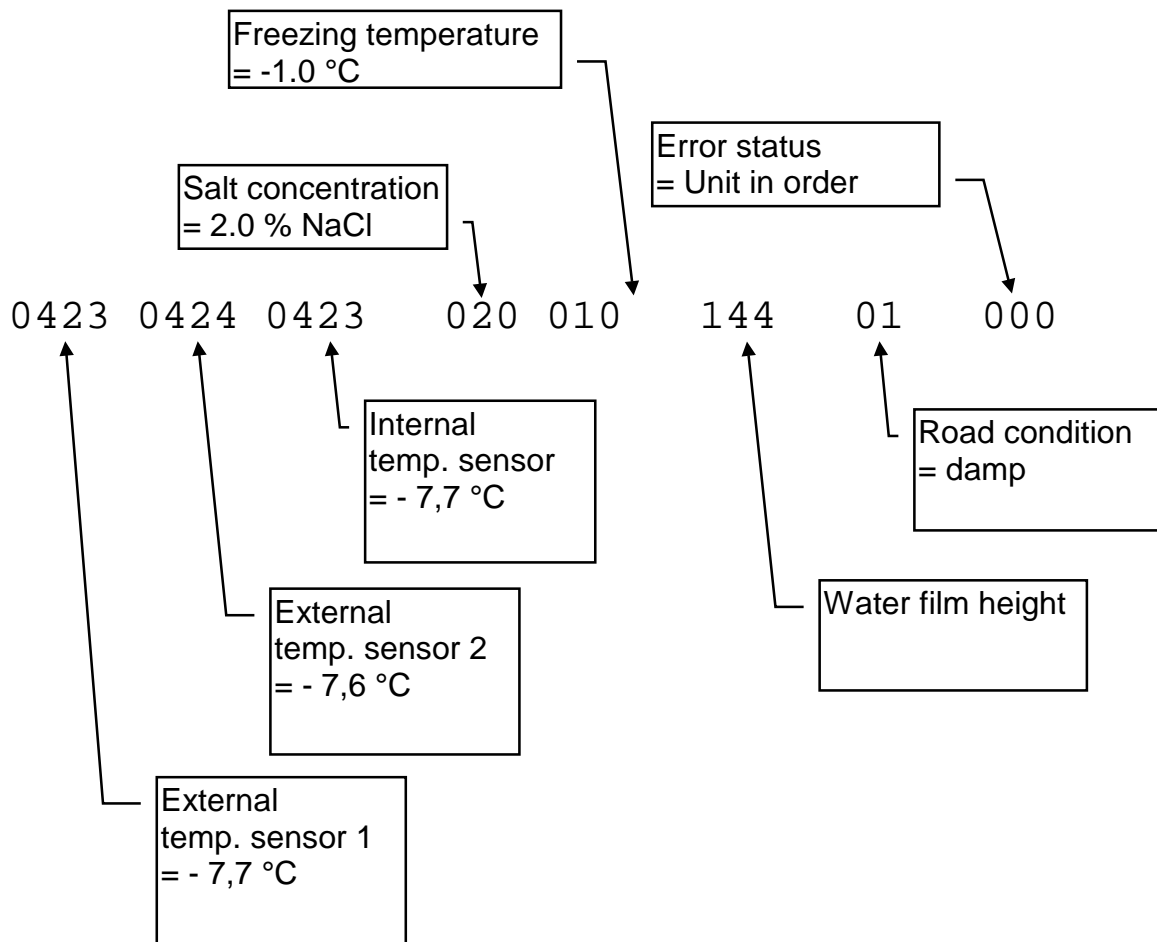

11.2.4 Binary Protocol (IRS-20 via OPUS200/300 <-> Host Computer)

11.3 Physical connection and hardware structure

The connection of the sensors to the traffic computer takes place via an OPUS 200 module. Two sensors can be connected to this module and these are joined together by a CAN Bus. Further modules can be added if necessary. Any of these modules can be an interface to the traffic computer (with one obligatory exception: not the module for the intelligent road sensor). The connection takes place via the RS232 interface. The baud rate is 19200 with 8 data bits, one stop bit and no parity. (8N1). All connected sensors can be addressed and interrogated via the RS232.

11.4 Software protocol

The addressing and interrogation of the sensors takes place through the host computer by means of a defined protocol. The host computer sends an inquiry telegram at specific intervals to each of the connected OPUS 200 modules. When the OPUS to which the serial interface is connected receives the telegram correctly it sends an ACK telegram. If an error was detected, it sends a NACK telegram. If the telegram was received correctly, the interrogated OPUS sends the current values back to the traffic computer.

The inquiry must be synchronous. The sensors and transmitters do not themselves initiate any information. The float measurement values are mapped in linear manner to a normalised value range from 0 - 65520, whereby 0 corresponds to the minimum measurement value and 65520 to the maximum measurement value of the configured sensor. Values above 65520 serve as error codes.

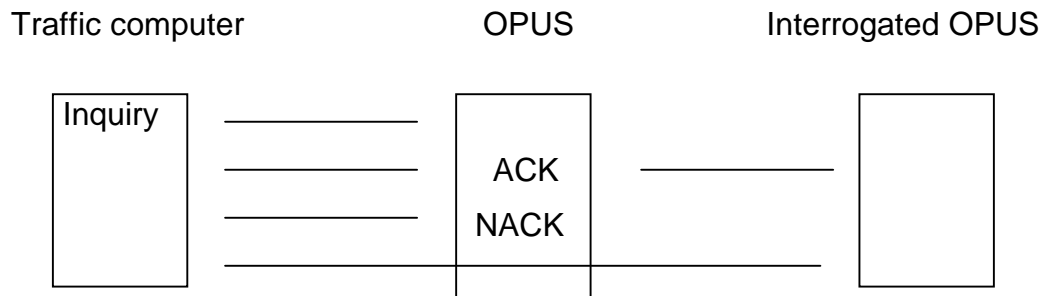

11.5 Telegram and data format

Data format:

LONG: LowLowByte LowHighByte HighLowByte HighHighByte

INT: LowByte HighByte

Telegram format

Inquiry telegram

Byte	1	2	3	4	5	6	7	8
Online data inquiry	?	N	x	x	x	x	c	c

x : Address of OPUS200 as LONG

cc: Horizontal check sum of all previous bytes as INT

Reply telegram

Byte	1	2	3	4	5	6	7	8	9	10	11	12
Online data reply for up to 4 measurement values	?	N	v	v	v	v	v	v	v	v4	c	c
For more than 4 measurement values a 2 nd	?	N	v	v	v	v	c	c	-	-	-	-
			5	5	6	6						

The measurement values including the road condition are transmitted to the transmission normal and must be correspondingly converted. The road condition is transmitted directly.

Error codes

The following error codes are defined:

Description	Value	
Value Overflow	0xFF 3	Outside the input range of the sensor, or no sensor was attached
Conf Error	0xFF 4	An unreasonable configuration was defined
Xor Error	0xFF 5	The check sum via E2 is incorrect
Invalid Value	0xFF D	

11.6 Configuration of the OPUS200 module

The configuration of an OPUS200 takes place using the software SmartControl. With SmartControl all sensors can be configured, with the exception of the Intelligent Road Sensor.

The configuration of an OPUS200 has a direct influence on the size and quantity of reply telegrams on an online inquiry (see reply telegram format).

Configuration of the Road Sensor

In order that an OPUS 200 can communicate with the road sensor it must be configured manually. This takes place in monitor mode by setting the E2 position 368 to the value 98 (connect OPUS 200 to the serial interface, switch into monitor mode with !xxxxx (xx = OPUS ID). The OPUS should output a short message to the terminal. In monitor mode describe the E2 position with the command **ES 368 98**. After restarting "FASS" should appear in the display.).

When an OPUS 200 is configured for the road sensor it has the following settings:

Sampling rate	60 seconds
Recording rate	10 minutes
Mode	Sleep mode

The values supplied (see Telegram format: Special case Intelligent Road Sensor) have the following meaning:

v1: Internal temperature sensor	Road surface temperature in range -50°C - 150°C
v2: External temperature sensor 1	Temperature of the first external temperature sensor in range -50°C - 150°C
v3: External temperature sensor 2	Temperature of the second external temperature sensor in range -50°C - 150°C
v4: Freezing temperature	Freezing temperature of the salt solution on the road in range -25°C - 0°C
v5: Water film height	Qualitative water film height
	0 Heavy water
	150 No water (zero load on radar sensor)
	250 Heavy ice
v6: Road condition	Road condition
	0 Dry
	1 Damp
	2 Wet
	3 Ice
	4 Frost / Snow
	5 Residual Salt
	6 Freezing Wetness
	99 Road condition not detectable

